

TWO HOUR AREA SEPARATION WALL
 NOTE: WE ARE ASSUMING THAT THE EXISTING EXTERIOR BUILDING WALL, WHICH IS CONSTRUCTED OF 4\"/>

EXISTING BUILDING

FELLOWSHIP HALL FOR: The Church of Christ 201 Fairview Road COLUMBIA, MO. 65203		mac S.A. MAGALLARI ARCHITECTS, INC. 1908 CHERRY HILL DR. STE. 301 COLUMBIA, MO. 65203 OFFICE: 573.876.0648 FAX: 573.876.0640	
CHURCH OF CHRIST ARCHITECTS 1908 CHERRY HILL DRIVE, STE. 301 COLUMBIA, MISSOURI 65203 TEL: 573-876-0648 FAX: 573-876-0640			
PROJECT NO. _____ DATE OF PLAN _____	SHEET NO. A2 TOTAL SHEETS _____	DRAWING PLAN REVISED PLAN	SCALE: 1/4" = 1'-0"

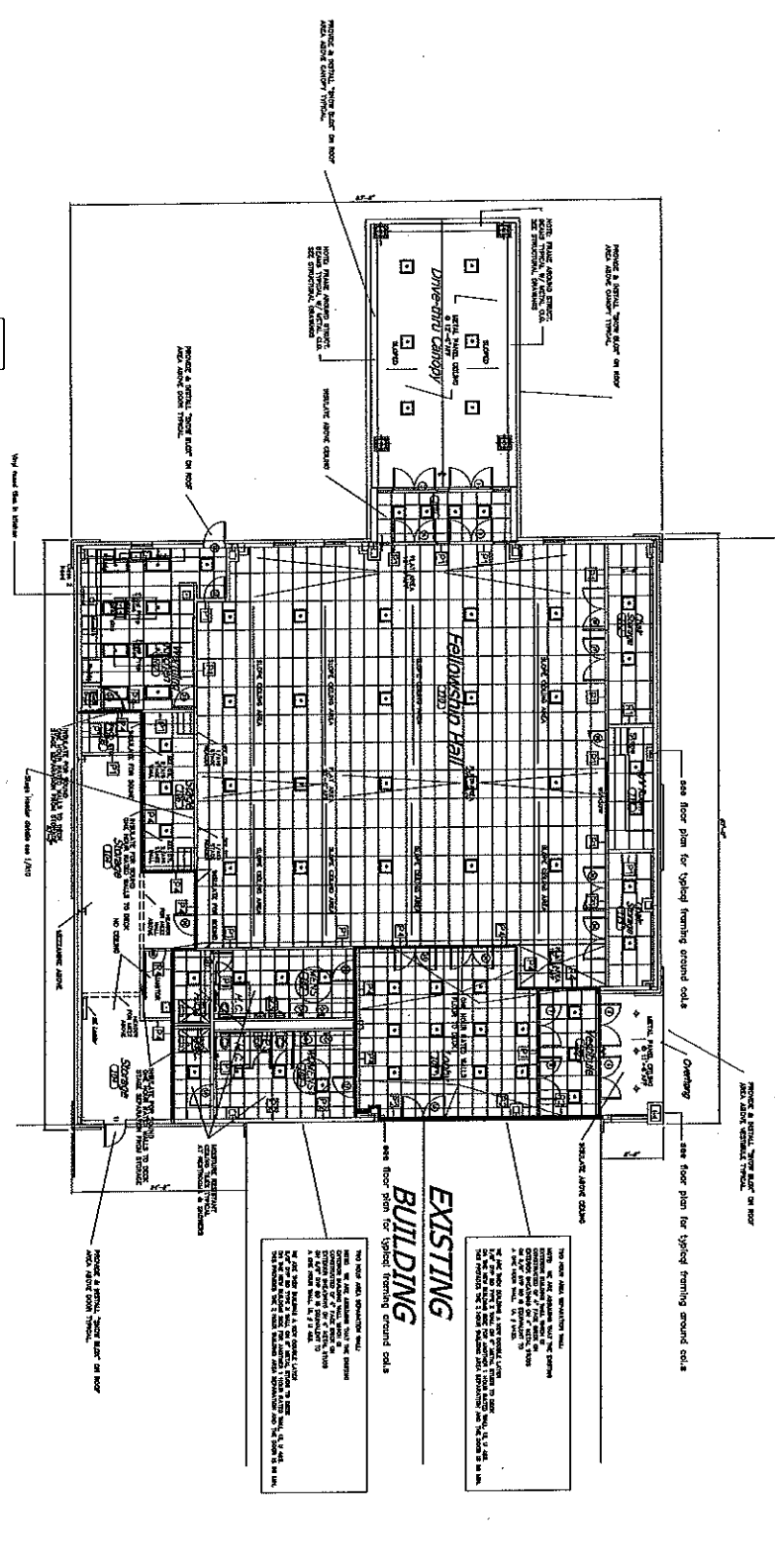
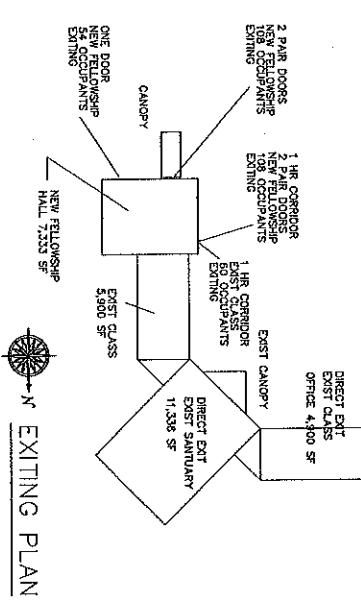

Ceiling Plan
 SCALE: 1/8" = 1'-0"

EXISTING BUILDING
 THIS EXISTING BUILDING SHALL BE DEMOLISHED AND RECONSTRUCTED TO BE A 15,000 SQ. FT. BLDG. WITH 15000 SQ. FT. OF FLOOR AREA. THE EXISTING BUILDING SHALL BE DEMOLISHED AND RECONSTRUCTED TO BE A 15,000 SQ. FT. BLDG. WITH 15000 SQ. FT. OF FLOOR AREA. THE EXISTING BUILDING SHALL BE DEMOLISHED AND RECONSTRUCTED TO BE A 15,000 SQ. FT. BLDG. WITH 15000 SQ. FT. OF FLOOR AREA.

EXISTING BUILDING
 THIS EXISTING BUILDING SHALL BE DEMOLISHED AND RECONSTRUCTED TO BE A 15,000 SQ. FT. BLDG. WITH 15000 SQ. FT. OF FLOOR AREA. THE EXISTING BUILDING SHALL BE DEMOLISHED AND RECONSTRUCTED TO BE A 15,000 SQ. FT. BLDG. WITH 15000 SQ. FT. OF FLOOR AREA. THE EXISTING BUILDING SHALL BE DEMOLISHED AND RECONSTRUCTED TO BE A 15,000 SQ. FT. BLDG. WITH 15000 SQ. FT. OF FLOOR AREA.

A3

FELLOWSHIP HALL FOR THE CHURCH OF CHRIST 201 FAIRVIEW ROAD COLUMBIA, MO. 65203
--

mac
 SAMCULLIN ARCHITECTS, INC.
 1905 CHERRY HILL DR. STE. 301
 COLUMBIA, MO. 65203
 OFFICE: 573.876.0640
 FAX: 573.876.0640

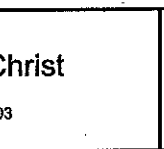

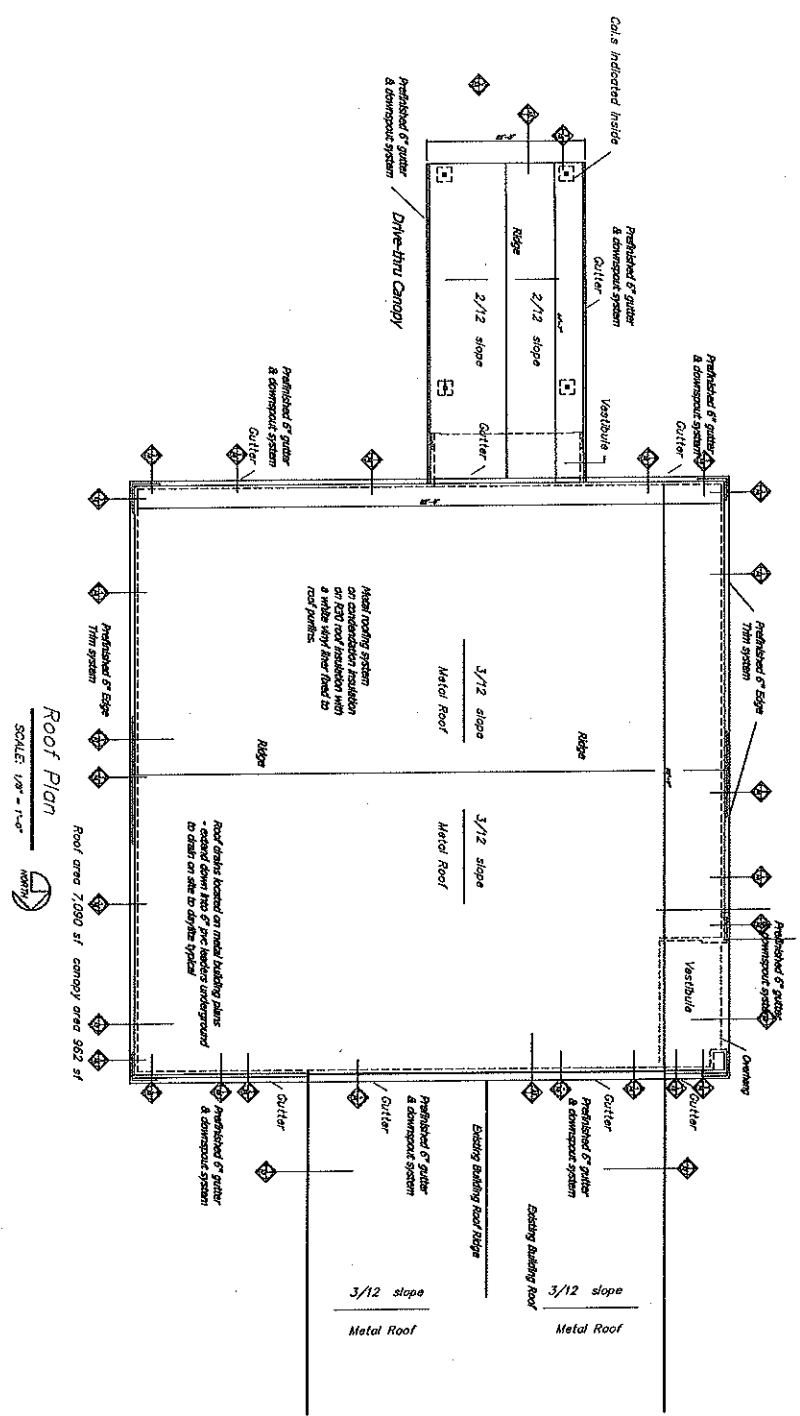

Roof Plan

SCALE: 1/8" = 1'-0"



Roof area 7,000 sf canopy area 802 sf

<p>A4</p>	DATE	SCALE
	<p>1/15/00</p>	<p>1/8" = 1'-0"</p>

NO.	DESCRIPTION	DATE
1	ISSUED FOR PERMIT	1/15/00
2	ISSUED FOR CONSTRUCTION	1/15/00
3	ISSUED FOR AS-BUILT	1/15/00
4	ISSUED FOR RECORD	1/15/00
5	ISSUED FOR ARCHIVE	1/15/00

FELLOWSHIP HALL FOR:
The Church of Christ
 201 Fairview Road
 COLUMBIA, MO. 65203

mac
 SAJCHMILLIN
 ARCHITECTS, INC.
 1905 CHERRY HILL DR. STE. 301
 COLUMBIA, MO. 65203
 OFFICE: 673.876-0648
 FAX: 673-878-0648





THE EXISTING
FOUNDATION
IS TO BE
REMOVED
AND THE
NEW
FOUNDATION
IS TO BE
CONSTRUCTED
AS SHOWN
HEREON.

SIMON ASSOCIATES INC.
13 South Sixth Street, Columbia, Missouri Phone: 573-774-9100 Fax: 573-774-8897

CHURCH OF CHRIST
261 FARMER AVENUE
COLUMBIA, MISSOURI

PROJECT No. 96-001
DATE ISSUED 02 / 13 / 97

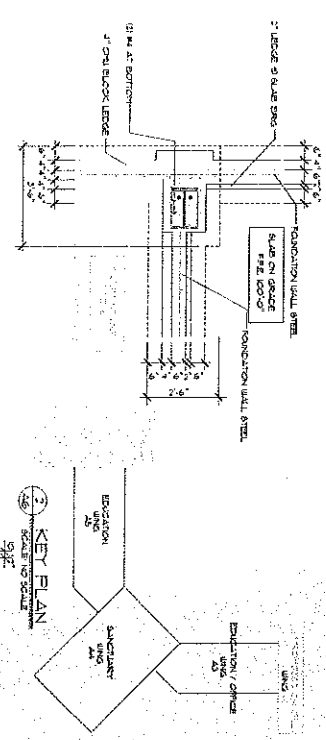

1 END SECT. & FELLOWSHIP - SIDEWALL
SCALE 1/4" = 1'-0"

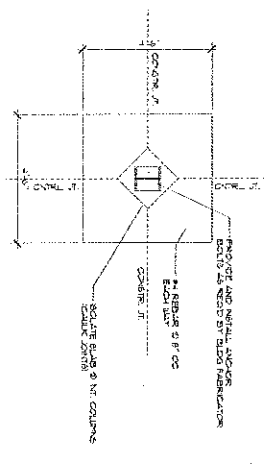

7 INTERIOR F.L.D. - PLAN DET.
SCALE 1/4" = 1'-0"

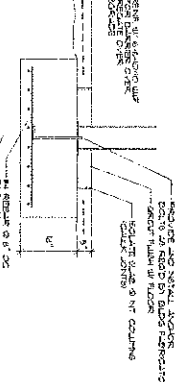

8 INTERIOR F.L.D. - SECTION
SCALE 1/4" = 1'-0"

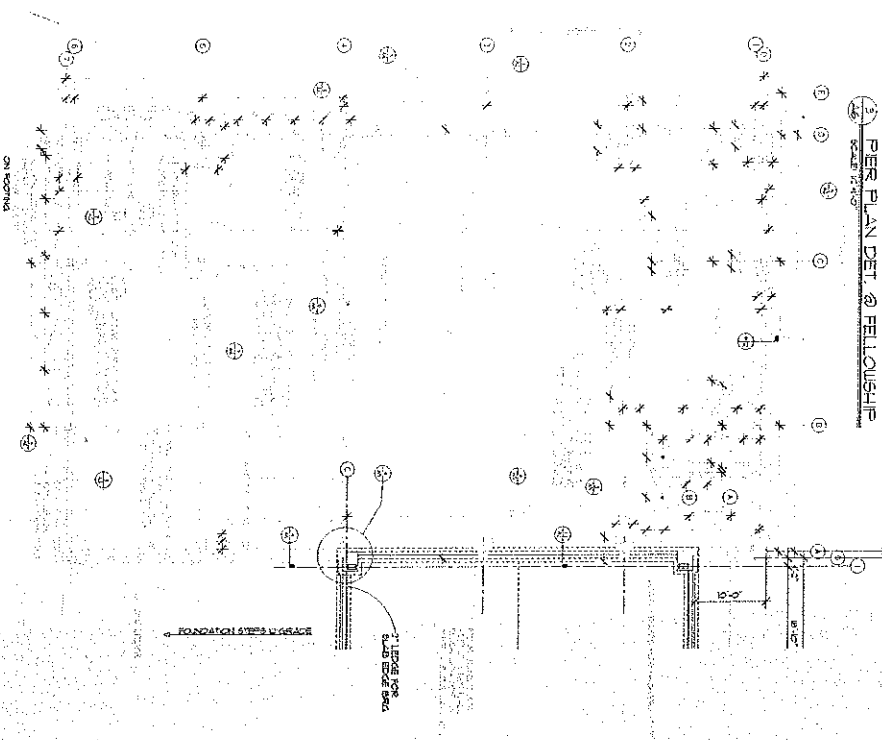

6 END SECT. & FELLOWSHIP - INT. WALL
SCALE 1/4" = 1'-0"

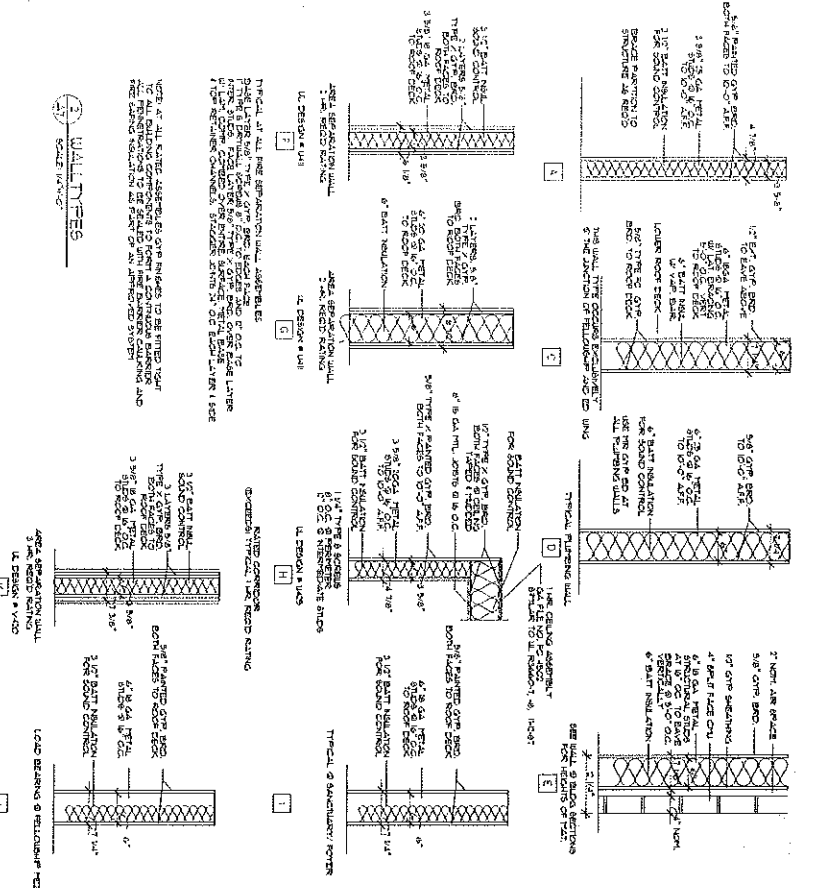
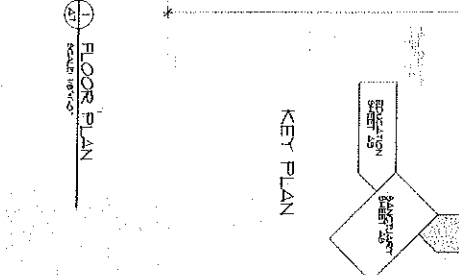
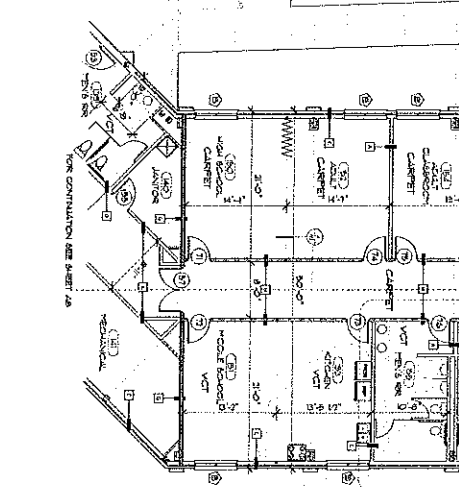
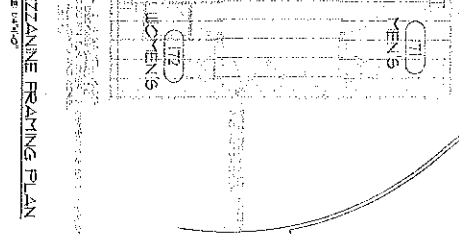
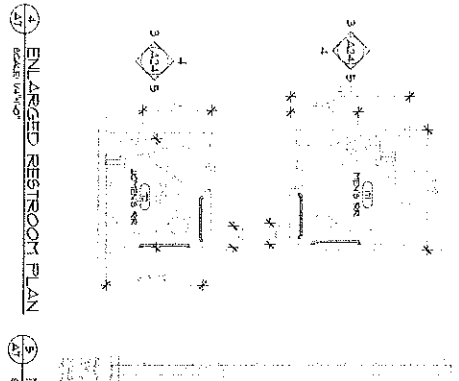
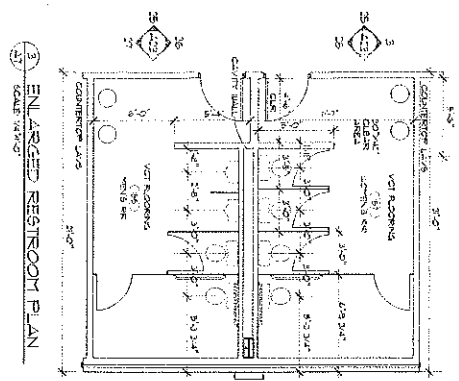

PROJECT NO. 94000
REVISIONS:
DATE ISSUED: 03 / 13 / 07

CHURCH OF CHRIST
281 FARMWAY ROAD
COLUMBIA, MISSISSIPPI

SIMON ASSOCIATES INC.
ARCHITECTURE
13 South 26th Street, Columbia, Mississ. Phone: 673-471-1710 Fax: 673-471-9417



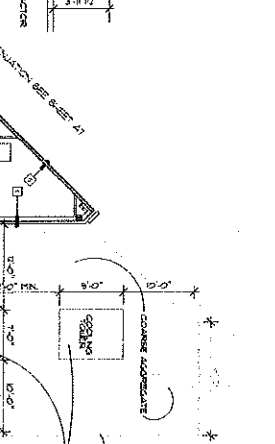
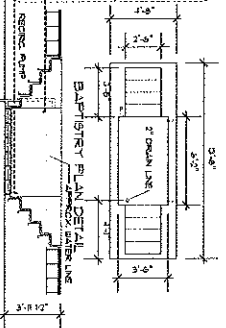
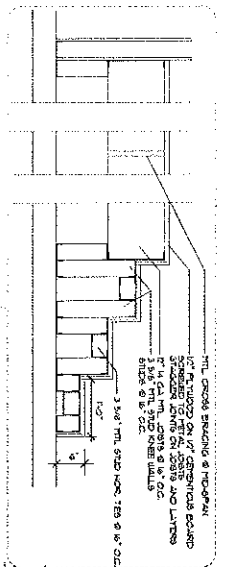

2 ENLARGED RESTROOM PLAN
SCALE 1/4" = 1'-0"

3 BAPTISTRY DETAIL
SCALE 1/4" = 1'-0"

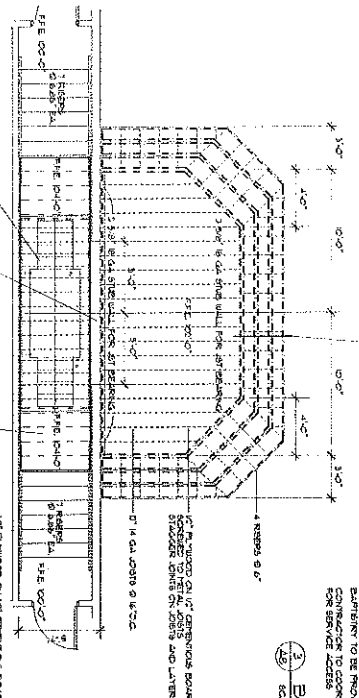

2 RAISED PLATFORM / HEATING
SCALE 1/4" = 1'-0"

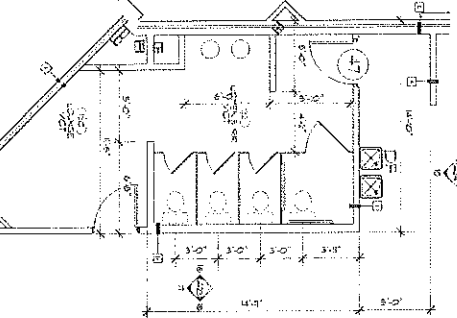

4 ENLARGED WOMEN'S RR PLAN
SCALE 1/4" = 1'-0"

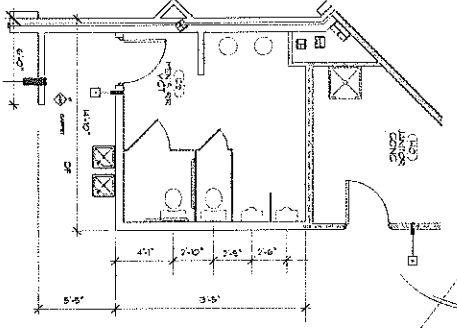

5 ENLARGED MEN'S RR PLAN
SCALE 1/4" = 1'-0"

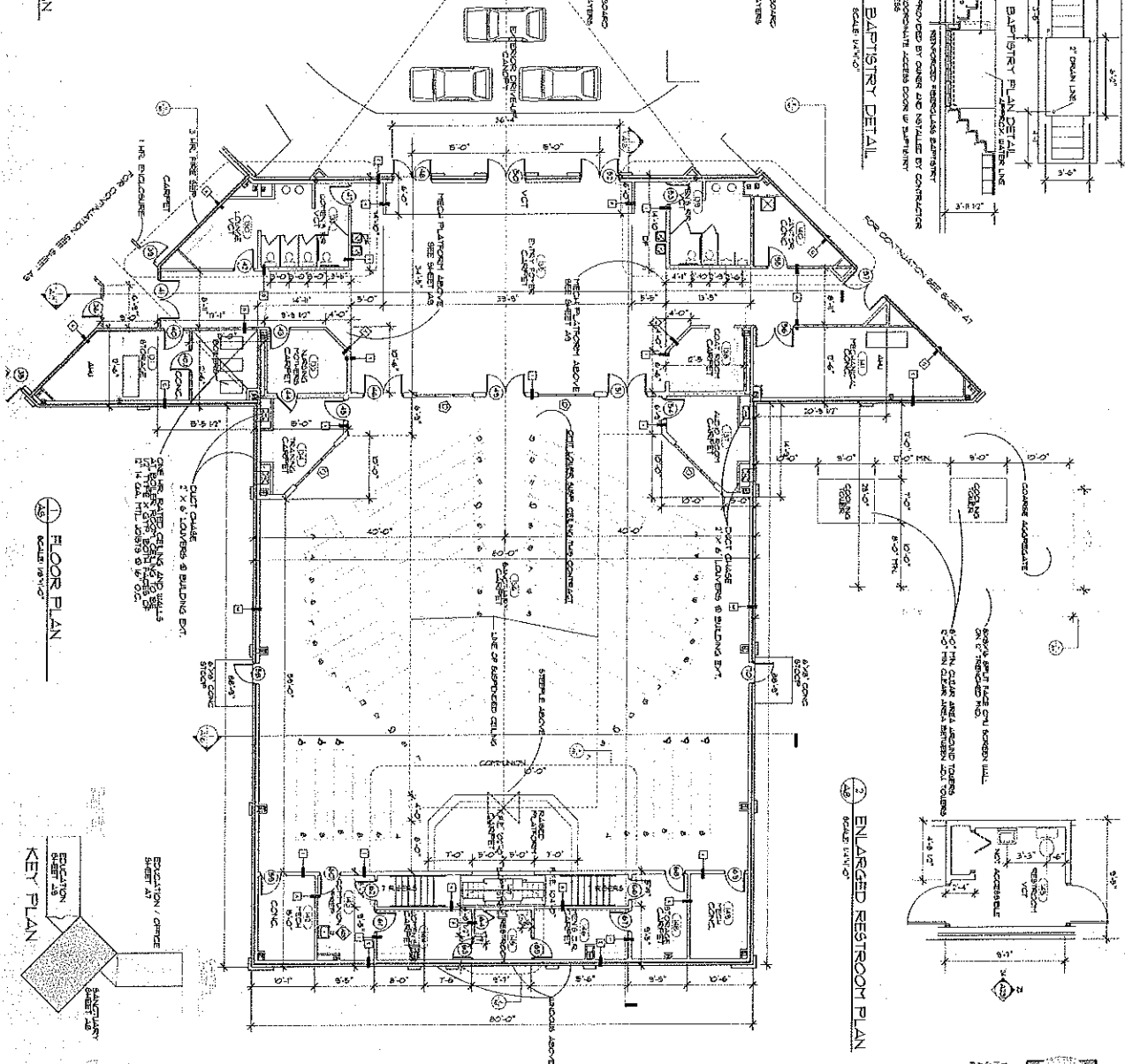

1 FLOOR PLAN
SCALE 1/8" = 1'-0"

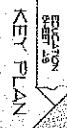

KEY PLAN

CHURCH OF CHRIST
201 FAULKNER ROAD
COLUMBIA, MISSOURI

SIMON ASSOCIATES INC.
ARCHITECTURE
13 South 5th Street, Columbia, Missouri Phone: 572-711110 Fax: 572-494477

PROJECT NO. 96-001
SCHEDULED START DATE 9/01/01
DATE ISSUED 03 / 13 / 02

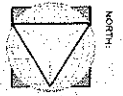

THIS DOCUMENT IS THE PROPERTY OF SIMON ASSOCIATES INC. IT IS TO BE USED ONLY FOR THE PROJECT AND SITE SPECIFICALLY IDENTIFIED HEREON.

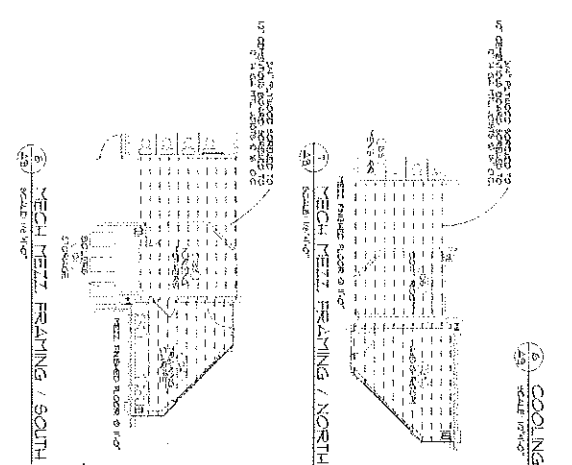

1 COOLING TOWER SCREEN DET
SCALE: 1/8\"/>

2 COOLING TOWER PAD
SCALE: 1/8\"/>

3 MECH NETZ FRAMING / SOUTH
SCALE: 1/8\"/>

4 MECH NETZ FRAMING / NORTH
SCALE: 1/8\"/>

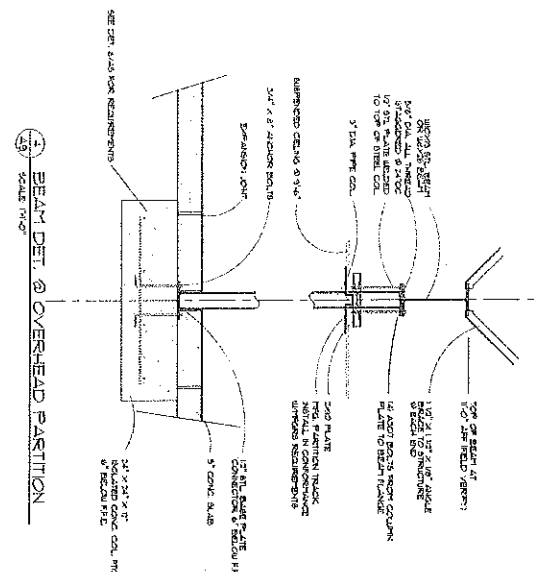

5 BEAM DET @ OVERHEAD PARTITION
SCALE: 1/8\"/>

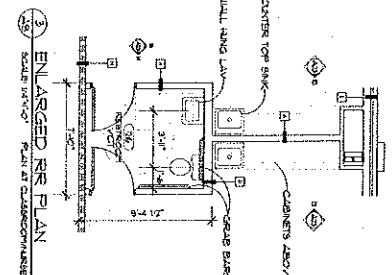

6 ENLARGED RISER PLAN
SCALE: 1/8\"/>

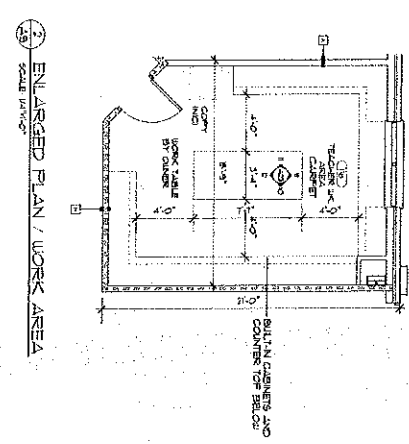

7 ENLARGED PLAN / WORK AREA
SCALE: 1/8\"/>

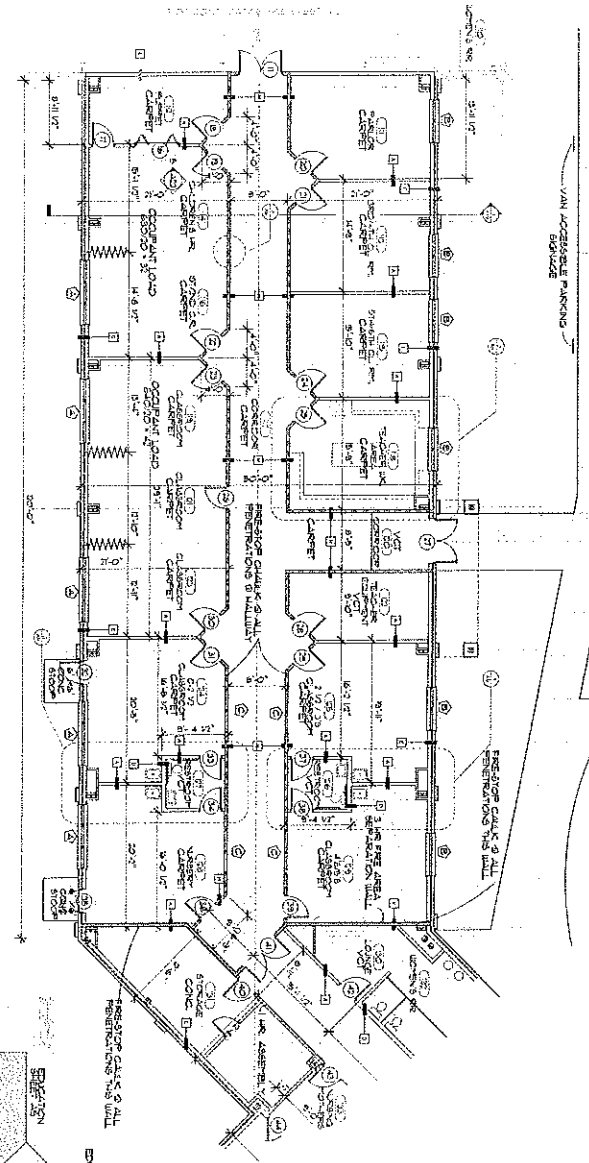

8 FLOOR PLAN
SCALE: 1/8\"/>

9 KEY PLAN
SCALE: 1/8\"/>

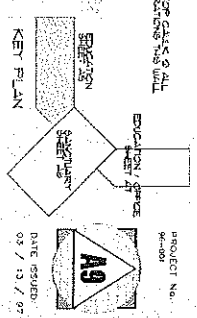

CHURCH OF CHRIST
261 FAIRVIEW ROAD
COLUMBIA, MISSOURI

SIMON ASSOCIATES INC.
BULLOCK ARCHITECTURE
112 South 24th Street, Columbia, Missouri Phone: 672-476-1818 Fax: 672-438-6427

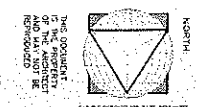

PROJECT NO. 49
DATE ISSUED: 02 / 13 / 97

3. BASEMENT FLOOR PLAN
SCALE: 1/8" = 1'-0"

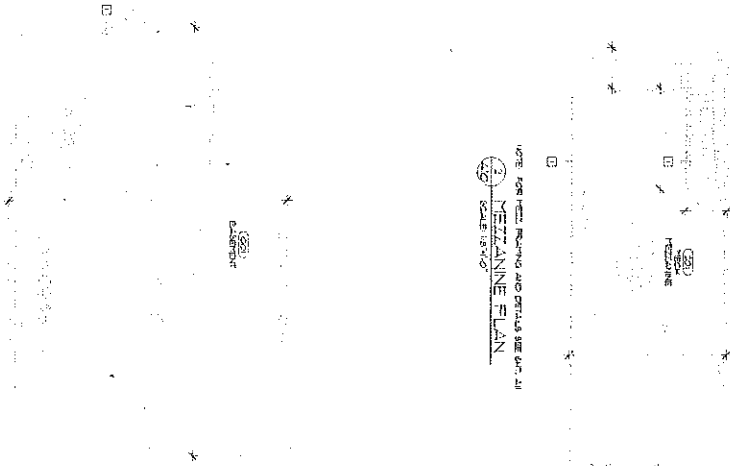

4. FLOOR PLAN
SCALE: 1/8" = 1'-0"

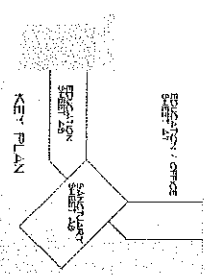
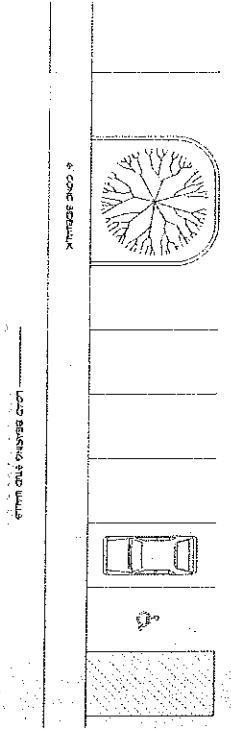
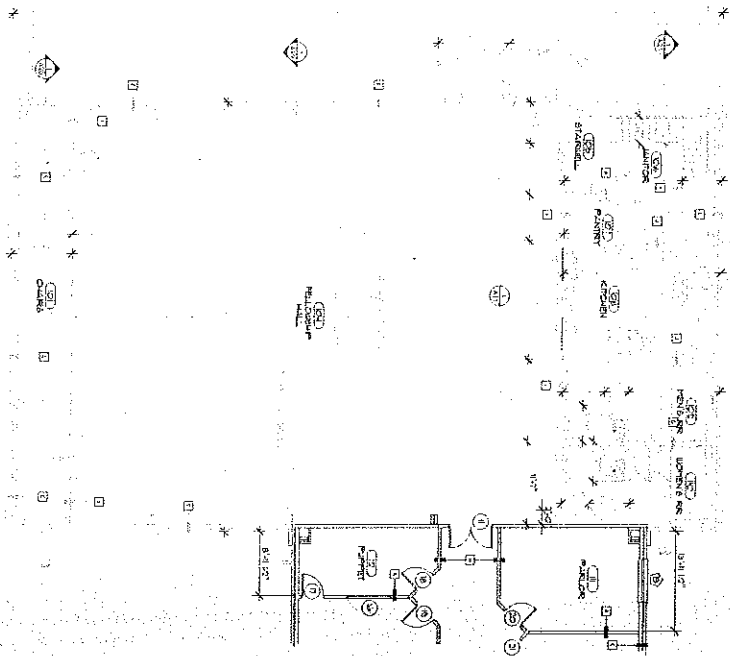

PROJECT NO. 18-001
DATE ISSUED: 03 / 13 / 97

CHURCH OF CHRIST
241 FAIRVIEW ROAD
COLUMBIA, MISSOURI

John Simon

SIMON ASSOCIATES INC.
13 South Kirk Street, Columbia, Missouri Phone: 573-474-1818 Fax: 573-456-6817

THIS DOCUMENT IS THE PROPERTY OF SIMON ASSOCIATES INC. AND IS NOT TO BE REPRODUCED OR TRANSMITTED IN ANY FORM OR BY ANY MEANS, ELECTRONIC OR MECHANICAL, INCLUDING PHOTOCOPYING, RECORDING, OR BY ANY INFORMATION STORAGE AND RETRIEVAL SYSTEM.

3 LOAD-BEARING PART. & NETZ
SCALE 1/8" = 1'-0"

7 LOAD-BEARING PART. & NETZ
SCALE 1/8" = 1'-0"

2 STAIR SECTION & FELLOWSHIP
SCALE 1/8" = 1'-0"

5 PLATFORM SECTION & FELLOWSHIP
SCALE 1/8" = 1'-0"

6 STAIR SECTION & PLATFORM
SCALE 1/8" = 1'-0"

4 STAIR SECTION & FELLOWSHIP
SCALE 1/8" = 1'-0"

1 MEZZANINE FRAMING PLAN
SCALE 1/8" = 1'-0"

2 RAISED PLATFORM FRAMING PLAN
SCALE 1/8" = 1'-0"

3 RAISED PLATFORM SECT.
SCALE 1/8" = 1'-0"

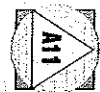

DATE ISSUED: 03 / 13 / 87

PROJECT NO. 88-001

REVISIONS:

CHURCH OF CHRIST
121 FAIRVIEW ROAD
COLUMBIA, MISSOURI

John E. Simon

SIMON ASSOCIATES INC.
BILL BULLOCK ARCHITECTURE & ENGINEERING
13 South Sixth Street Columbia, Missouri Phone: 672-476-1110 Fax: 672-419-6417

THIS DOCUMENT IS THE PROPERTY OF SIMON ASSOCIATES INC. AND IS NOT TO BE REPRODUCED WITHOUT PERMISSION.



NORTH